



MEDIUM GROUND MOBILITY SYSTEM

MEDIUM GROUND MOBILITY SYSTEM

The Medium Ground Mobility System improves the mobility of vehicles with pneumatic tyres by creating an access route that stabilises the ground when ground bearing pressure is very low.

The system comprises of M30H Trackway®, an aluminium panel, graded as Military Load Classification (MLC) 30 baseline on 3% California Baring Ratio ground conditions indefinitely, and loads of up to MLC 40 dependent on the ground conditions.

Versatile in its capability, the M30H Trackway® panel is the ideal solution for approach roads, gap crossing, temporary roadways, beach landings, and flooring.

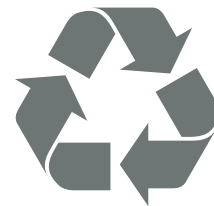



**Over the shore
mobility made easy**

M30H TRACKWAY®

M30H Trackway® (originally MLC 30) is graded as Military Load Classification (MLC) 30 baseline on 3% California Bearing Ratio ground conditions indefinitely, and loads of up to MLC 40, dependent on the ground conditions.

CAPABILITY

- ✓ Creates roadways that can withstand traffic from vehicles with pneumatic tyres;
- ✓ Creates access and egress points from ships for beach landings;
- ✓ Facilitates vehicle access across terrains with low California Bearing Ratio (CBR);
- ✓ Avoids environmental damage caused by wear and tear from vehicle traffic
- ✓ Withstands loads in excess of 30T depending on the ground conditions and length of use;
- ✓ Provides a high traction surface;
- ✓ Reusable for multiple operations in any environment.





SPECIFICATION

✓	Modular design which allows for parts to be easily replaced if necessary;
✓	Divided panels at 9m intervals to ensure easy assembly, splitting and joining;
✓	Withstands temperatures ranging from -40°C to +60°C for maximum usability;
✓	Does not float and is therefore suitable for use in flowing water;
✓	100% recyclable and has residual value at the end of its useful life;
✓	Easily cleaned due to the open nature of the profile, minimising retention of debris;
✓	Reusable for multiple operations in any environment;
✓	Dual directional rolling functionality allows improved conformity over uneven ground;
✓	Quick release locking bolts with robust slide in/slide out locking mechanism;
✓	Grip enhancing grooves provide grip when dirty therefore no maintenance is required.



SHIPPING FRAME

Loaded by crane, tele-handler or forklift, the shipping frame stores and transports a Spool holding up to 40m of M30H Trackway®, whilst also holding the accessory box, tie down points, lifting points and forklift pockets.

DIMENSIONS

	Full Panel	Half Panel
✓ Width:	3,354mm	1,677mm
✓ Length:	244.4mm overall	244.4mm overall
✓ Effective Length:	231.8mm effective	231.8mm effective
✓ Height:	25.5mm	25.5mm
✓ Weight:	14.8kg	7.4kg
✓ Weight / Area:	19kg kg/m ²	19kg kg/m ²

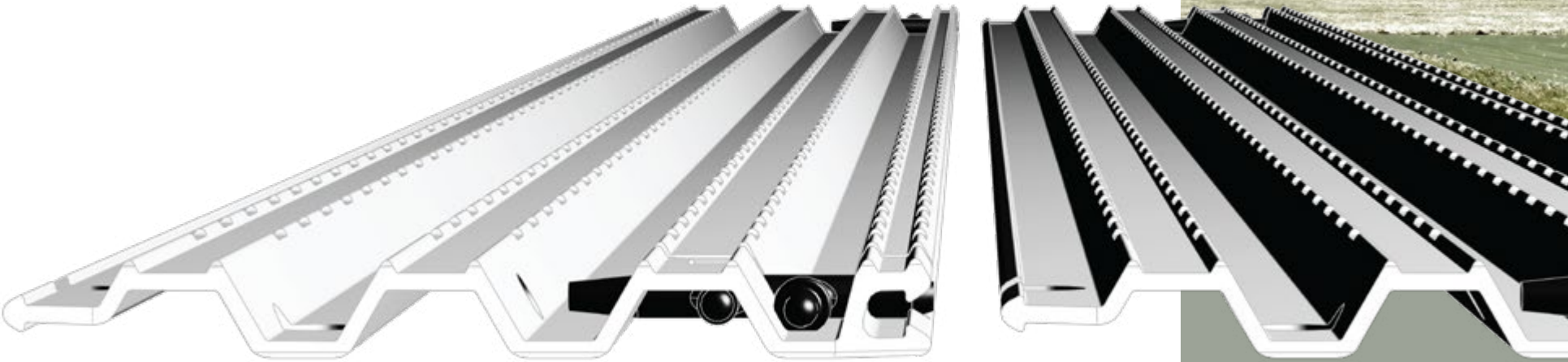



DEPLOYMENT OPTIONS

FASTRACK

The Fastrack is a specifically designed launch and recovery system which can transport and store up to 32m of M30H Trackway® using minimal manpower and can be mounted to any 4x4 or 6x6 flatbed vehicle or chassis. The panels are coiled onto a Spool which is part of the Fastrack. The Spoolframe rotates 90° and the vehicle reverses to deploy the M30H Trackway®. The process is reversed to pick up the M30H Trackway® at the end of use, ready to be deployed elsewhere, when and where it is required.

CAPABILITY



Deploys M30H Trackway® quickly and easily;



Provides a streamlined transportation system for M30H Trackway®;



Saves time, and requires minimal manpower (two individuals).



PLAY VIDEO





SPECIFICATION

✓	Infra-red or wireless control system (optional);
✓	CARC coating (optional);
✓	ISO twist-locks for easy transportation by rail or road (optional);
✓	95% recyclable components;
✓	Hydraulically driven;
✓	NATO IRR paint.

DIMENSIONS

✓	Width:	2,150mm
✓	Length:	4,600mm
✓	Height:	1,850m
✓	Weight: Fastrack:	875kg
✓	Weight: 32m M30H Trackway®:	4,200kg

MEDIUM BEAM DISPENSER

The Medium Beam Dispenser transports, stores, deploys and recovers up to 40m of M30H Trackway®. Compatible with front-end loaders and telescopic handlers, the Medium Beam Dispenser is suitable for multi-role operations, where many 40m lengths of M30H Trackway® are required to create a long access road or large hard standing area.

CAPABILITY

- ✓ Deploys 40m of M30H Trackway® in under three minutes from an interchangeable Spool;
- ✓ Requires only two personnel - one plant operator and one ground guide;
- ✓ Ensures that the M30H Trackway® is deployed under constant tension;
- ✓ Tele-handler, telescopic forklifts and wheeled loader compatible subject to specification;
- ✓ An empty Spool can be released and replaced with a new full spool in under five minutes;
- ✓ Withstands ambient temperatures ranging from -40°C to +60°C.



PLAY VIDEO





SHIPPING FRAME

The shipping frames store and transport the Medium Beam Dispenser with one full Spool holding up to 40m of M30H Trackway®. Each shipping frame comprises of an accessory box, tie down points, lifting points and forklift pockets.

SPECIFICATION

✓	Steel construction with hydraulic motor (minimum requirement 40l/m, 210bar);
✓	Suitable for mineral oil and biodegradable oil;
✓	Connected to host plant using quick hitch and quick release hydraulic couplings;
✓	Electrical connections not required;
✓	The Spool is locked in place by secured manual locking levers;
✓	Spooling in and out is controlled by auxiliary hydraulic circuit of the host machine.

DIMENSIONS

✓	Width:	4,280mm
✓	Length:	2,010mm
✓	Height:	1,430mm
✓	Weight: Medium Beam Dispenser :	500kg
✓	Weight: 40m M30H Trackway® :	3,450kg



PUSHBAR

The Pushbar is a galvanised steel device, designed to roll out and recover up to 40m of M30H Trackway® by use of a vehicle with a minimum of 3,500kg tow capacity, and either:

- ✓ A towing hitch or pin suitable for a 76mm diameter towing eye;
- ✓ 51mm trailer towing hitch ball.

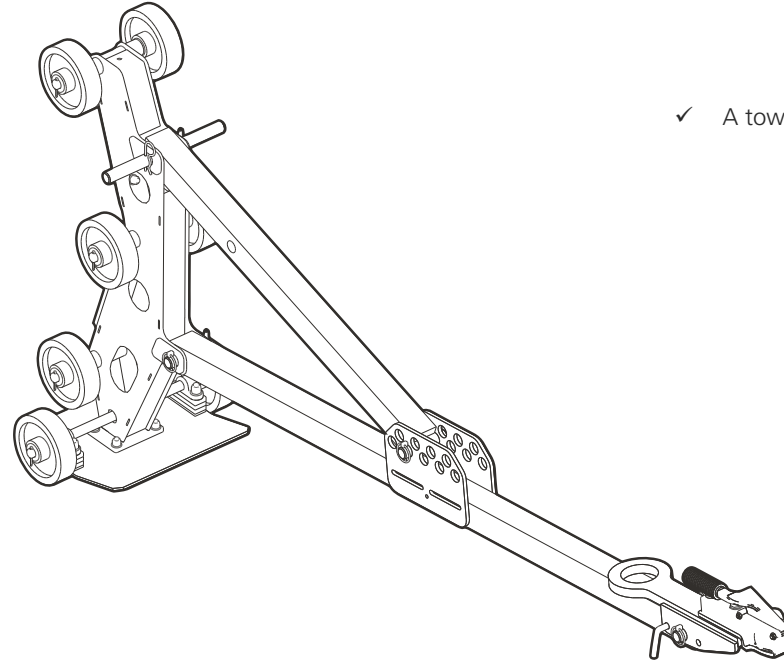

	Stowed	Deployed
✓ Width:	518mm	518mm
✓ Length:	2,225mm	2,256mm
✓ Height:	366mm	975mm
✓ Weight:	63kg	63kg



FAUN Trackway Limited

Member of the KIRCHHOFF Group

Unit 6, Bryn Cefni Industrial Estate
Llangefni, Anglesey, North Wales
LL77 7XA, UK

Tel: +44 (0) 1248 722 777

Fax: +44 (0) 1248 750 490

info@fauntrackway.co.uk

www.f auntrackway.co.uk

Images for Illustration Purposes Only

Registered in England and Wales 09283749

All content © FAUN Trackway Limited 2025. All Rights Reserved