

TRACKWAY[®] DEFENSE



 **FAUN**[®]
TRACKWAY USA

OUR HERITAGE

FAUN Trackway USA, Inc. has a prestigious reputation, with over 75 years' experience in the design and manufacture of premium products and tailored solutions.

Originally Saunders-Roe based on the Isle of Wight, we relocated to Anglesey during the 1940s, and later in 1968, we became Laird (Anglesey) Ltd. In 1996, we were acquired by the KIRCHHOFF Group; a family-run, German group of engineering and manufacturing companies that have been providing innovative solutions for over 220 years.

Our highly skilled and experienced team continue to design and manufacture ground stabilization Trackway® products for defence operations; and, as the global leader, our solutions are now in use by Armed Forces worldwide.



www.faustrackway.com



“

Our products
are unsurpassed
in functionality,
quality and
durability

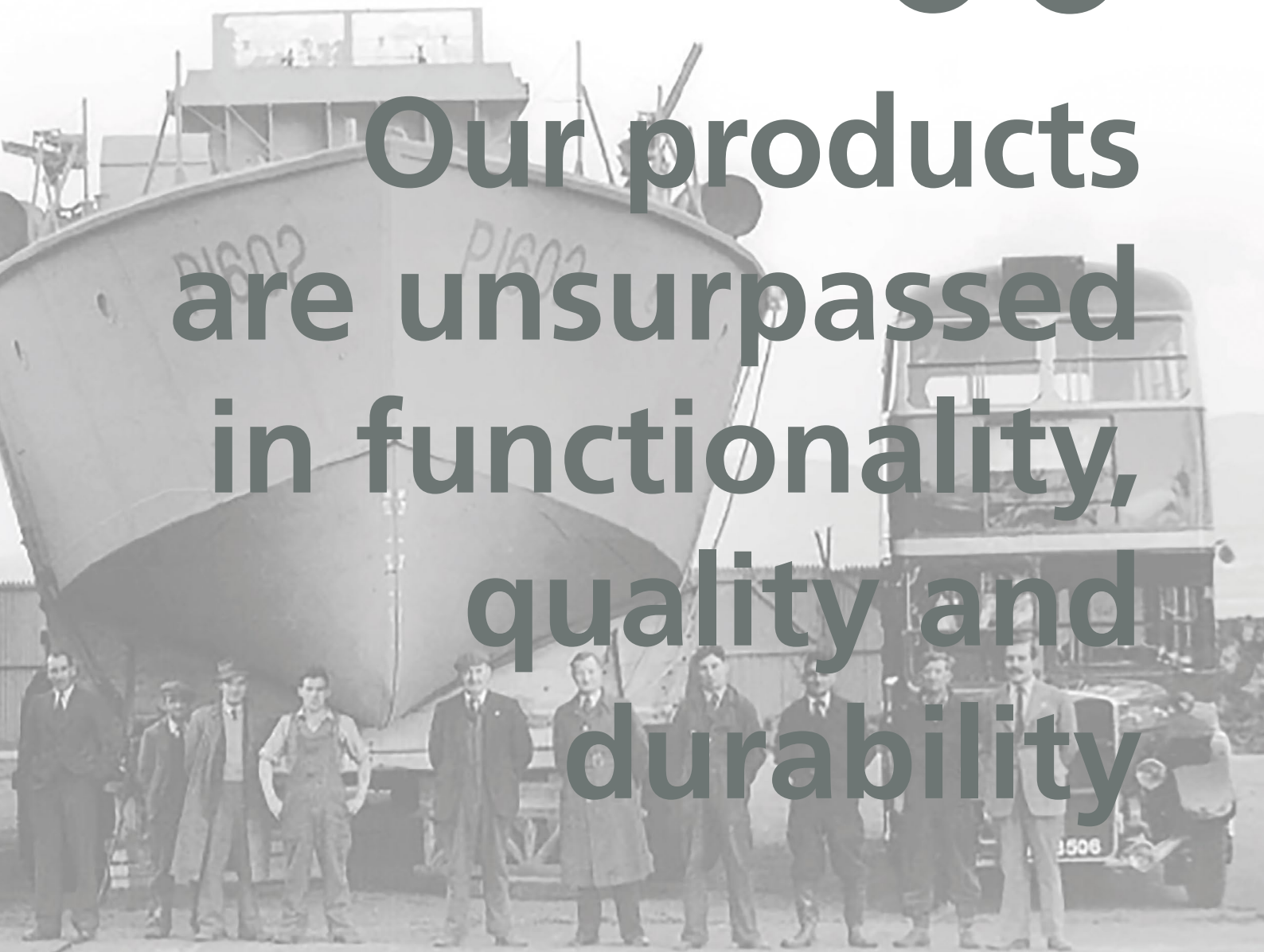

KEEPING YOUR MISSION ON TRACK

Navigating difficult physical surroundings often impairs planning and movement, whether on the battlefield or in areas stricken by natural disaster. Our range of aluminum Trackway® solutions are used in a variety of front line and humanitarian situations. The multi-purpose panels are portable, allowing for safe, temporary access routes and landing areas for vehicles and aircraft.



RAPIDLY DEPLOYED

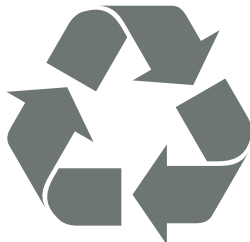

PROTECTS ENVIRONMENT



LIGHTWEIGHT

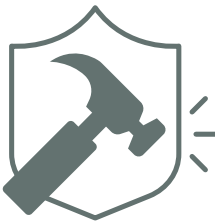

DURABLE

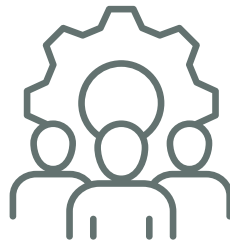

MINIMAL MANPOWER

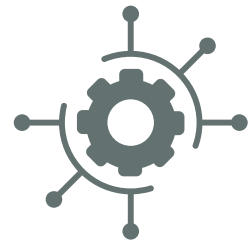

MULTI-PURPOSE





HEAVY GROUND MOBILITY SYSTEM

The Heavy Ground Mobility System creates a modular, aluminum access route to improve the mobility of vehicles and aircraft. Best suited to adverse terrain conditions, including snow, marsh, mud, and sand, the system is suitable for heavy tracked and wheeled vehicles, including tanks, tank carriers, and bridge transporters.

The system comprises of a deployment and recovery mechanism, and M150 Trackway® which is the ideal solution for route clearance, bridging ingress and egress, helipads, parking areas, runways, and over the shore operations.

The renowned M150 Trackway® is graded as Military Load Classification (MLC) 70 baseline on 3% California Baring Ratio ground conditions, and loads of up to MLC 150 dependent on the ground conditions.

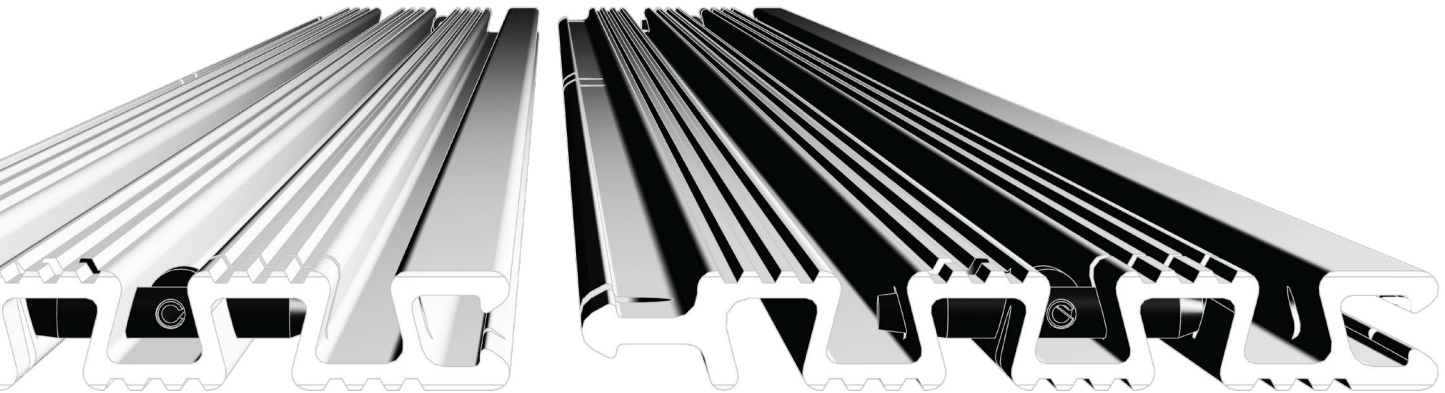

DEPLOYMENT OPTIONS

	CAPACITY	HOST VEHICLE	RESOURCES	OTHER
TRACKRACK®	164ft M150 Trackway®	6x6 or 8x8 DROPS chassis	1 operator 1 driver 10 minutes	Additional 164ft can be stored on Spoolrack which is transferred to Trackrack® once the 164ft is deployed.
INDEPENDENT TRACKRACK®	98ft M150 Trackway®	6x6 or 8x8 container frame chassis	1 operator 1 driver 10 minutes	Built-in independent power unit provides electrical and hydraulic requirements.
HEAVY BEAM DISPENSER	98ft M150 Trackway®	Front-end loader / telescopic handler with min handling capability of 12T	1 operator 1 driver 8 minutes	Suitable for multiple operations where additional lengths are deployed to create a long access route.

ADDITIONAL OPTIONS

HEAVY CONTAINER

Deploys and recovers 295ft of M150 Trackway® by 2 personnel in under 8 minutes by a Rough Terrain Container Handling Vehicle.

PUSHBAR

A lightweight deployment device which, when attached to a vehicle, will unroll up to 65ft of M150 Trackway®.

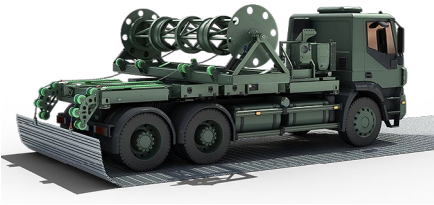

MEDIUM GROUND MOBILITY SYSTEM

The Medium Ground Mobility System improves the mobility of vehicles with pneumatic tyres by creating an access route that stabilises the ground when ground bearing pressure is very low.

The system comprises of M30H Trackway®, an aluminium panel, graded as Military Load Classification (MLC) 30 baseline on 3% California Baring Ratio ground conditions indefinitely, and loads of up to MLC 40 dependent on the ground conditions.

Versatile in its capability, the M30H Trackway® panel is the ideal solution for approach roads, gap crossing, temporary roadways, beach landings, and flooring.

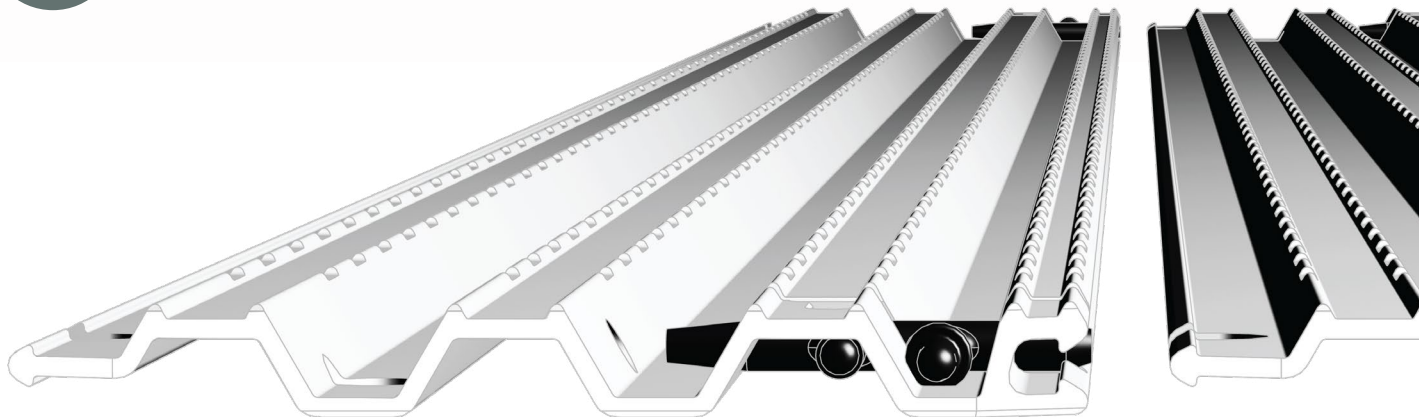

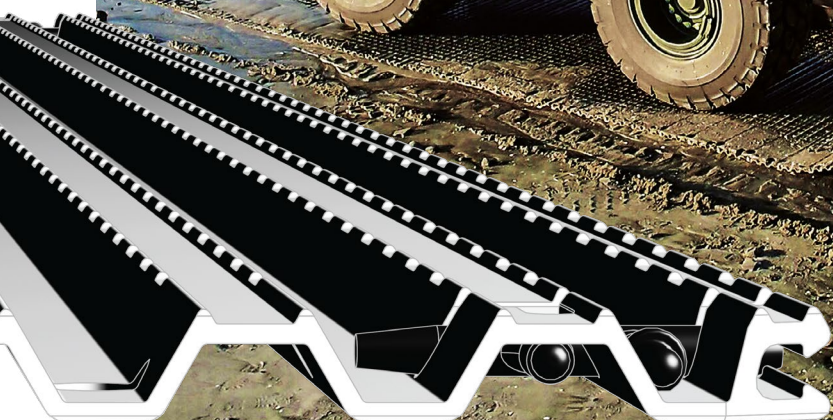

DEPLOYMENT OPTIONS

FASTRACK

The Fastrack is a specifically designed launch and recovery system which can transport and store up to 164ft of M30H Trackway® using minimal manpower. The Fastrack is crane mounted to any 4x4 or 6x6 flatbed vehicle or chassis via twistlocks.



MEDIUM BEAM DISPENSER

The Medium Beam Dispenser deploys and recovers up to 131ft of M30H Trackway®. Compatible with front-end loaders and telescopic handlers, it is suitable for multi-role operations, where additional 131ft lengths of M30H Trackway® can be joined together to create a long access road.

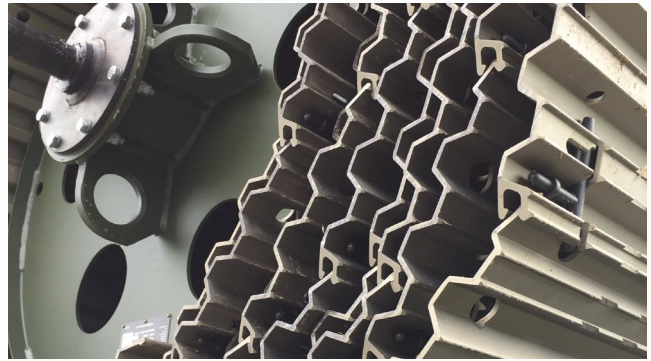

PUSHBAR

A lightweight deployment device which when attached to a vehicle, will unroll up to 131ft of M30H Trackway®.

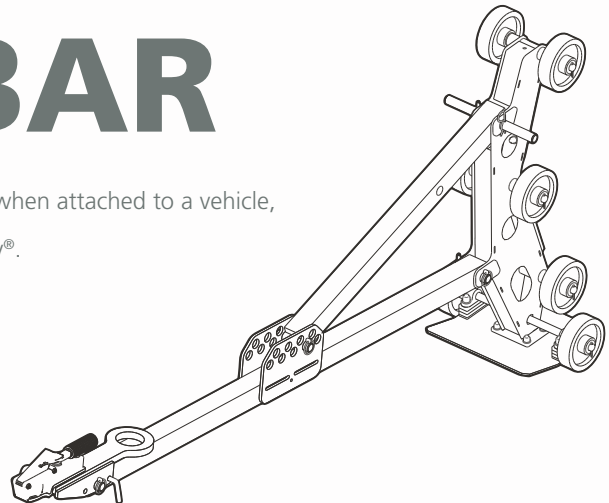

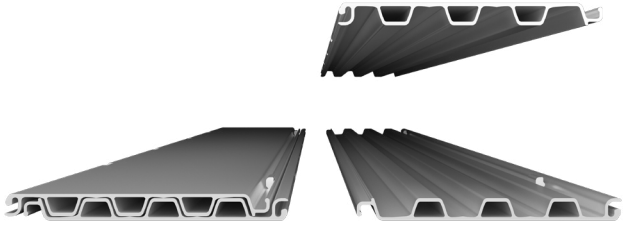

PSA Flat Top N Trackway®

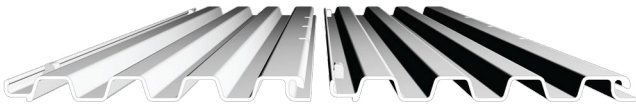

PSA Trackway®

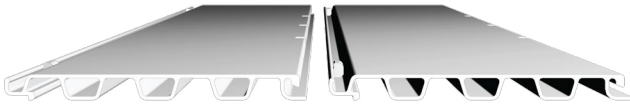

PSA Flat Top Trackway®



PSA Flat Top R Trackway®



HELICOPTER LANDING MAT

Our Helicopter Landing Mat system allows expeditionary forces create safe landing, servicing, parking and take-off areas for all types of helicopters. The system suppresses dust and foreign objects, ensuring pilot and crew safety as well as asset protection. Developed for the UK Royal Engineers, the Helicopter Landing Mat is available in a variety of panel profiles and created to any size requirement.



AIRCRAFT LANDING MAT

A modular aluminum panel system that is the perfect alternative solution to concrete or asphalt runways. This innovative product allows expeditionary forces to build runways, taxiways and parking areas in scenarios where there is no time, requirement or ability to install a permanent airfield. Reusable for multi-operations, the system is available in a variety of Trackway® panel profiles, each suited to a group of aircraft and requirement, ensuring maximum usability.



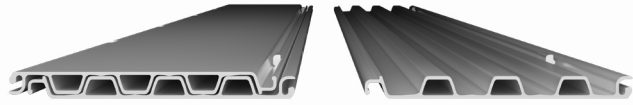

PSA Flat Top N Trackway®

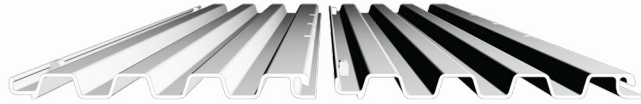

PSA Trackway®

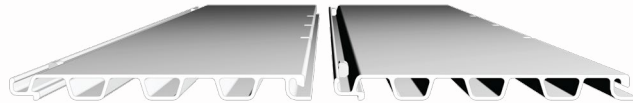

PSA Flat Top Trackway®



PSA Flat Top R Trackway®



S46H Trackway®

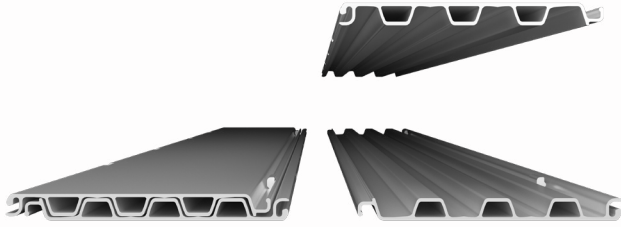

PSA Flat Top N Trackway®

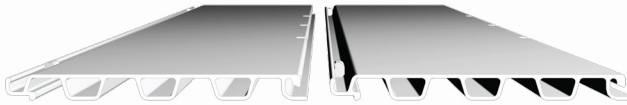

PSA Flat Top Trackway®



PSA Flat Top R Trackway®



S46H Trackway®





UAV LANDING MAT

The UAV Landing Mat is the epitome of landing mat technology evolution. Tried, tested and recommended by the Engineering Research and Development Centre for Reaper and Predator loadings, this solution is versatile, reusable and 100% recyclable. With a choice of aluminium Trackway® panels, the UAV Landing Mat has been specifically designed to create runways for UAV and drone operations.

The system can be supplied to your exact requirement, and is air transportable on NATO 463L pallets. Rapidly deployed in time critical scenarios, the UAV Landing Mat can be recovered just as quickly when required in an alternative location.







RAPID RUNWAY REPAIR

Following an enemy attack, it is vital that operations can be resumed quickly. Rapid Runway Repair is an integral part of the Airfield Damage Repair process, which is essential in the capability of a base to 'Survive to Operate', developed by the UK Armed Forces and understood to be one of the most professional solutions in NATO.

The system enables the reconstruction of essential areas of the airfield, forming a Minimum Operating Strip and allowing for an emergency runway for operations to resume. Comprising of M150 Trackway® Bomb Damage Repair Mat, the system can be supplied to suit any size requirement, and can be re-purposed when not required.



INTEGRATED LOGISTICS SUPPORT

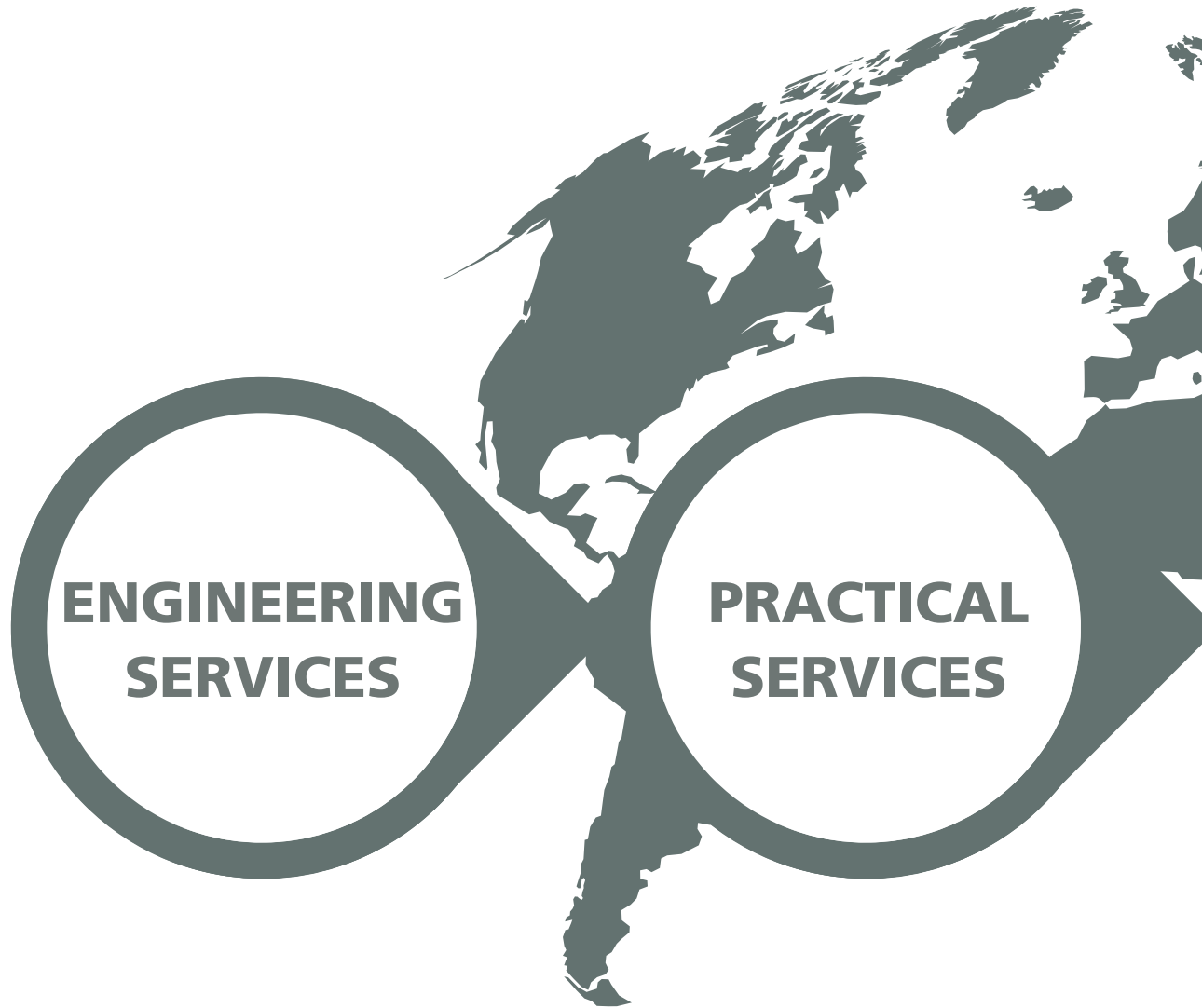

We consider Integrated Logistics Support to be a top priority; one in which the fundamentals focus on design, engineering and manufacture. Our client support does not end at providing top quality equipment, but starts at the beginning of the acquisition process, advising during the specification design stages and after contract award with an immediate design review.



**USER
SERVICES**

**LIFECYCLE
SERVICES**



TESTIMONIALS

Brigadier Carell, Army Chief of Land Forces, Sweden

It is unusual to have a project delivered ahead of time. Well done to the FAUN Trackway® team.

Lieutenant Colonel Stefan Axelsson – Head Of Development, Swedish Engineer School

This equipment has a superior quality and operates effectively in all conditions including extreme climates such as arctic conditions.

Per Arne Johnson, Principal Officer - Head of Contract Office, Kolsaas, Norway

After an extensive period of testing and trials the Norwegian Defence Procurement division placed an order for 8 HGMS. Since delivery, they have been in active use in both the north and south of Norway and in missions abroad. HGMS has given us mobility capability that we did not have before the procurement. The system is easy to operate, has excellent build quality and operates effectively in all conditions.

Marcus Rubi, Engineer – Rescue Material and NBC Protection, Armasuisse, Switzerland

This was the first time Switzerland had entered into such a co-operation with another country (Sweden), and it was surprising how successful this had been.

Danish Acquisition and Logistics Organisation

We were impressed how FAUN Trackway® approached our brief, and the ease and speed in which the team went from concept to fully-functioning prototype. We are confident that with this order we will significantly enhance our capabilities in difficult environments.

Christian Gnaegi, Project Manager Engineer – Equipment from Armasuisse the Competence Centre for Procurement within the Federal Department of Defence

We would like to praise the high level of professionalism of the employees at FAUN Trackway®. We can confirm that the team fulfilled the technical requirements and all stipulations. We are looking forward to future co-operation.



FAUN Trackway USA, Inc.

Member of the KIRCHHOFF Group

Office #630, 2611 South Clark Street,
Arlington, VA, 22202-4046, USA

Tel: +1 (620) 912 8752

info@fauntrackway.com
www.f auntrackway.com

Images for Illustration Purposes Only

DUNS # 968299268

CAGE # 6HLG9

All content © FAUN Trackway USA, Inc. 2026. All Rights Reserved.